

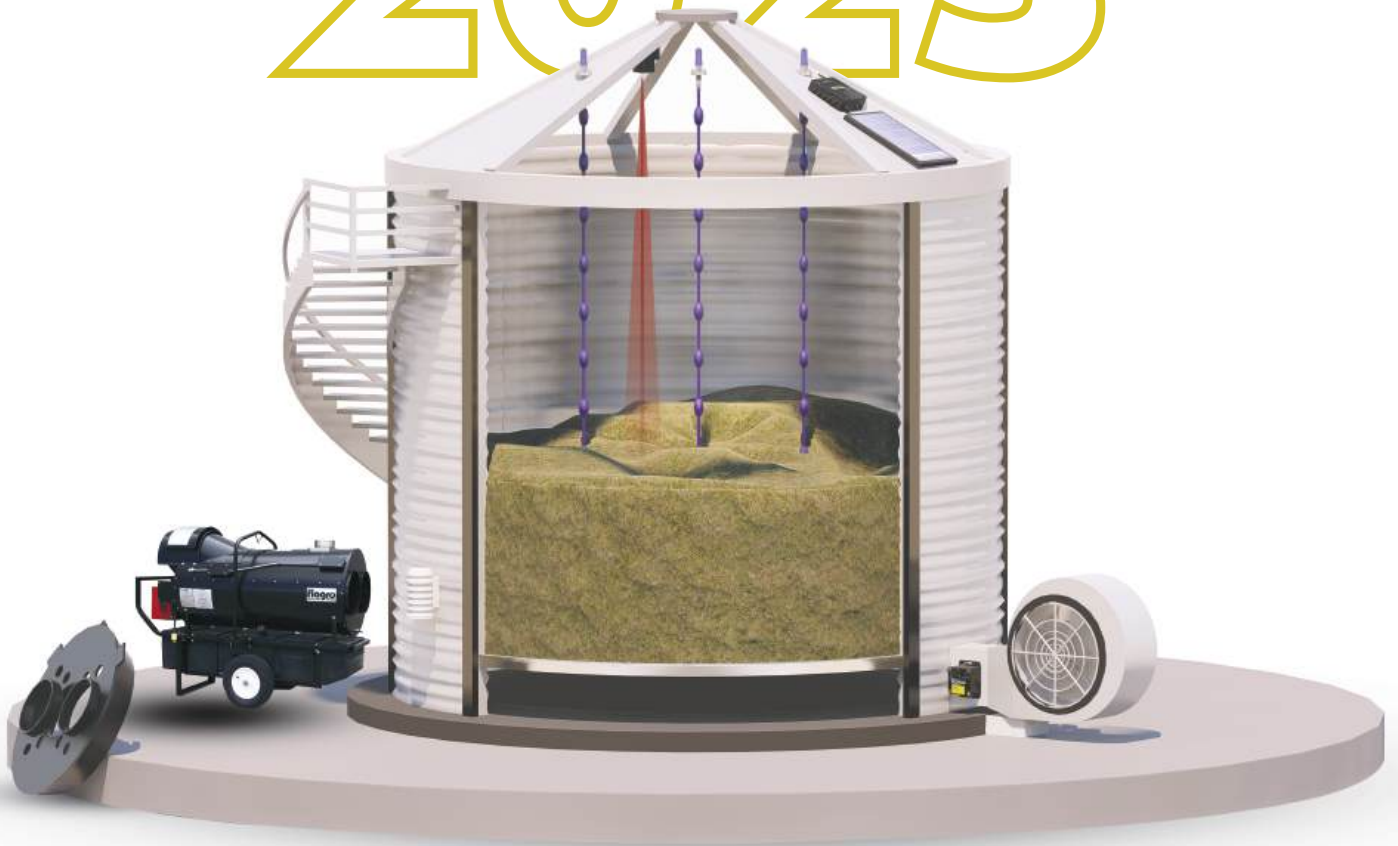

**Grain Monitoring & Automation
Made Simple.**

PRODUCT GUIDE
2025



www.adaptiveagriculture.ca

 306.850.1259

 sales@adaptiveagriculture.ca



Content

How Bindapt Works

Modular Design

Device: Inputs and Outputs Explained

Bindapt+ Device: Monitor/Control

Plenum Sensor

Ambient Sensor

Headspace CO2 Sensor

Heater+ Control Module

Aeration + Control Module

Adapter Plates

Aeration Transitions

Visual Farm Platform Features:

- Bins: Inventory Management

- One-Click Bin Modes: Drying, Hydrating, Cool-down & Storage

- Plot your Bins and Bin Yards

- Map your Fields: Scouting and Crop Traceability

- Teams: Collaborate as a Team in one place

- Platform Integrations: Forward Looking

HOW BINDAPT WORKS

Bindapt+ is an IoT Device that connects to Sensors (inputs) and Controller (outputs) to Monitor grain quality and Control conditions within the Bin. The user accesses the Bin Information and control options via the online platform on Desktop or Mobile devices. Below is a diagram of a complete bin conditioning system from Adaptive Agriculture:

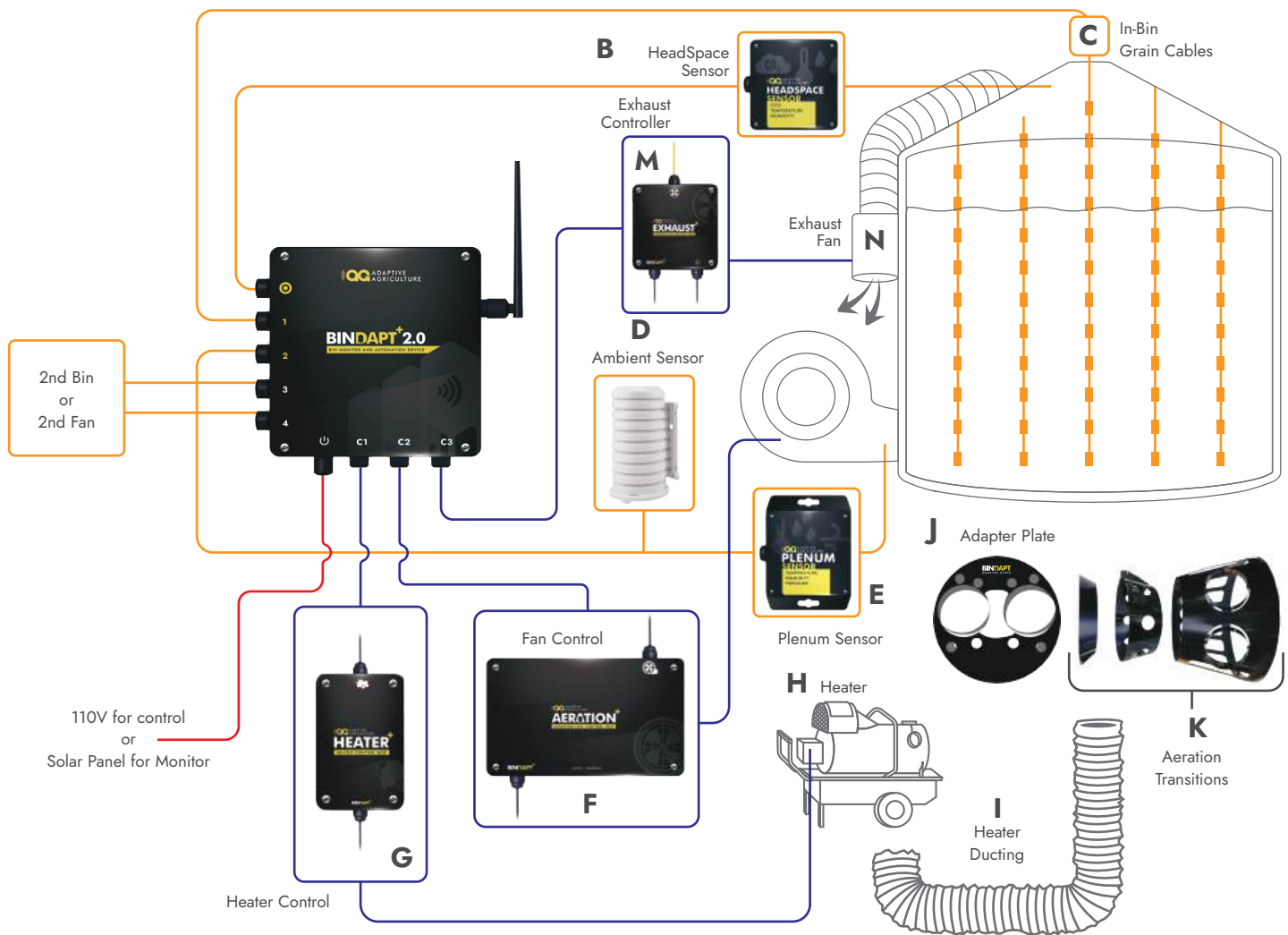

Legend for Diagram

Legend	Product Name	Product Type	Use Cases
A	Bindapt+ Device	IoT Device	Master Unit: Wi-Fi or Cellular Connectivity. Connects to All Sensors and Controllers
B	Headspace CO2 Sensor	Sensor	CO2, Temperature & Humidity Headspace Sensor for Early Spoilage Detection
C	In-Bin Grain Cables	Sensor	Temperature & Humidity Sensors for In-Bin Monitoring, Conditioning & Alerts
D	Ambient Sensor	Sensor	Temperature & Humidity Sensor for Natural Air Drying and/or Hydration Automation
E	Plenum Sensor	Sensor	Temperature, Humidity & Static Pressure Sensor for In-Bin Drying, Hydrating, and Aeration Performance
F	Aeration+ Fan Controller	Controller	Modular Controller to Automate the Aeration Process and give Remote Connectivity
G	Heater+ Heater Controller	Controller	Modular Controller to Automate a Construction Heater for Supplemental Heat Drying
H	Construction Heater	Aeration / Drying	Mimic the perfect drying conditions with a Construction Heater added to the Aeration Process
I	Performance Ducting	Aeration / Drying	Custom Designed and manufactured heater ducting for positive and negative pressure flow
J	Adapter Plates	Aeration / Drying	Easily attach The Construction Heater Ducting to the Inlet of the aeration Fan
K	Aeration Transitions	Aeration / Drying	Different Transitions are attached to the Adapter Plate for different Size Fans, used for In-Bin Drying
L	Aeration Fans	Aeration	Proper Aeration is key to In-Bin Conditioning, Drying, and Hydrating Grain.
M	Exhaust+ Fan Controller	Aeration	Modular Controller to Automate the operation of an Exhaust Fan to reduce condensation when in-bin grain drying.
N	Exhaust Fan	Aeration	Portable exhaust fan that mounts on your bin ladder to suck high moisture air from the top of the grain bin.

MODULAR DESIGN

The Bindapt+ system's modularity is a key advantage, allowing users to tailor their monitoring and conditioning solution to meet their specific needs. Its adaptable design enables easy configuration and the addition of modules to create the perfect solution. Users can expand their system as their requirements evolve, integrating additional sensors, controllers, or features to enhance monitoring precision and conditioning capabilities.

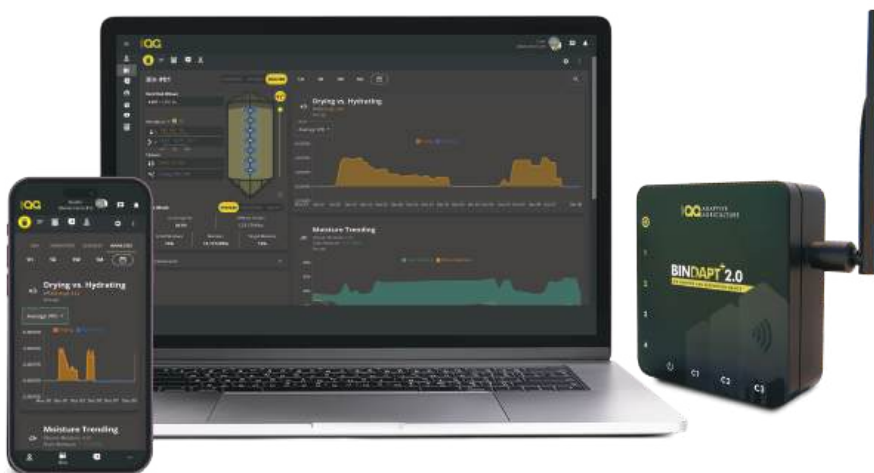

This modularity not only provides flexibility but also future-proofs the system, ensuring it can grow in tandem with their operation's demands. Whether it's scaling up for larger storage facilities or incorporating new technology advancements, the Bindapt+ system's modular approach ensures users can continuously refine and customize their grain management solution to achieve optimal results.

DEVICE: INPUTS AND OUTPUTS EXPLAINED

SENSOR INPUTS

- In Bin Grain Cables
- Plenum Sensor
- Headspace CO2 Sensor

POWER:

- 12VDC (PSU supplied)
- Solar Panel (Sold Separately)

MODULAR OUTPUTS

- Aeration Fan
- Supplemental Heater
- Exhaust Fan

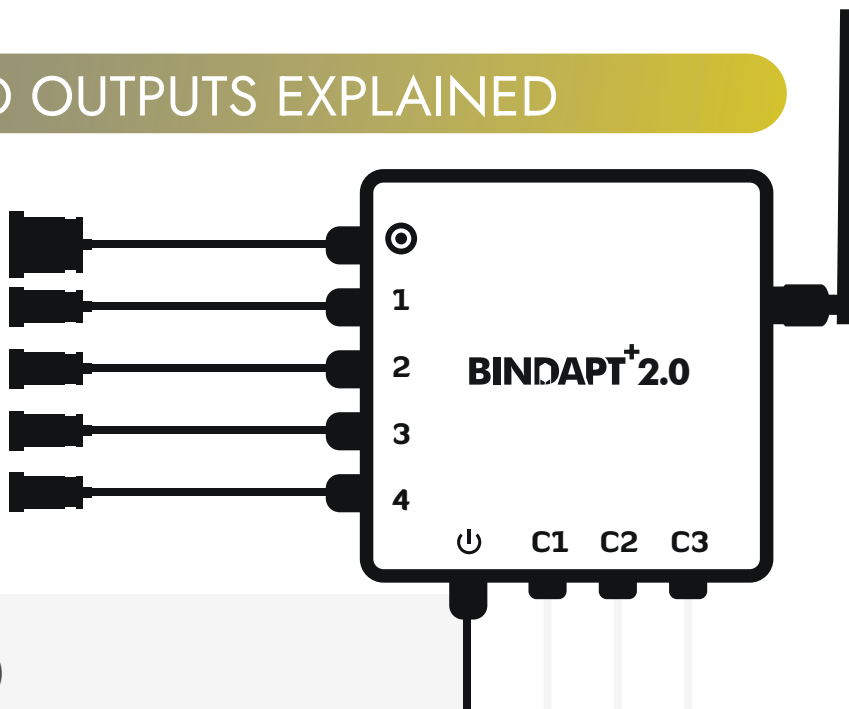

BINDAPT+ DEVICE: MONITOR/CONTROL

Part ID: BDM001 / BDC001

The Bindapt+ 2.0 is the brain of the smart bin technology. The Bindapt+ 2.0 is capable of Cellular or Wi-Fi connectivity and is accessed through Adaptive Agriculture's Visual Farm Platform

The device is connected to a bin and can read:

- ▷ In Bin Grain Cables (OPI & Bin-Sense)
- ▷ Plenum Sensor (Pressure, Temperature/Relative Humidity)
- ▷ Headspace Sensor (CO2 and LiDAR Level Sensing)

The control outputs on the bottom of the device can control:

- ▷ Aeration Fan (Aeration+ Control Module)
- ▷ Construction Heater (Heater+ Control Module)
- ▷ Exhaust Fan (Exhaust + Control Module)

Power Requirements are:

1. Standard 12VDC North American Power Adapter Supplied (Power is required if using control outputs)
2. Solar Panel (Sold Separately)

Benefits of Monitoring Device:

1. Live Updates to your Mobile device: SMS and Email Alerts.
2. Temperature and Moisture Monitoring and Alerts for Spoilage Detection
3. Expandable with CO2 headspace sensing for early spoilage detection (up to two weeks before cables heat)

Benefits of Control Device

1. Dry, Hydrate, and Cool-Down grain with one-click Bin Modes
2. Automate the conditioning process with modular control outputs (Aeration Fan, Supplemental Heat, and Exhaust)



PLENUM SENSOR

Part ID PS001

The Plenum Sensor measures **Temperature, Humidity, and Static Pressure** in the plenum. These measurements are further analyzed in the Adaptive platform to indicated CFMs and the ability for the air to hydrate or dry your grain.

Mounting Flanges:

Rigid mounting flanges to secure the Plenum Sensor onto the plenum of the aeration system.



Temperature & Humidity

The Temperature and humidity sensors are used to measure the quality of the air entering your bin. When combined with an in bin moisture cable, our platform will indicate how well you are drying or hydrating your grain during aeration.



Measure Aeration Fan Performance

The Static Pressure sensor measures the pressure within the plenum and is matched against your aeration fan chart to give you an airflow in CFM.

The Plenum Sensor is used to detect fan performance and is a critical tool for providing analysis on drying and hydrating efforts. The Plenum Sensor is a Temperature, Relative Humidity and Static Pressure sensor that plugs into any of the 2-pin input ports of the Bindapt+ One.

Main Benefits of the Plenum Sensor:

- ▷ **Real-Time Fan Performance:** Converts Pressures into CFM based on Fan Type and Size
- ▷ **Monitor the Aeration Process:** Know the exact temperature and moisture entering your grain bin.
- ▷ **Control the Air:** Combined with the Heater+ Control Module and a construction heater the user can set parameters and maintain temperatures and humidities entering the bin

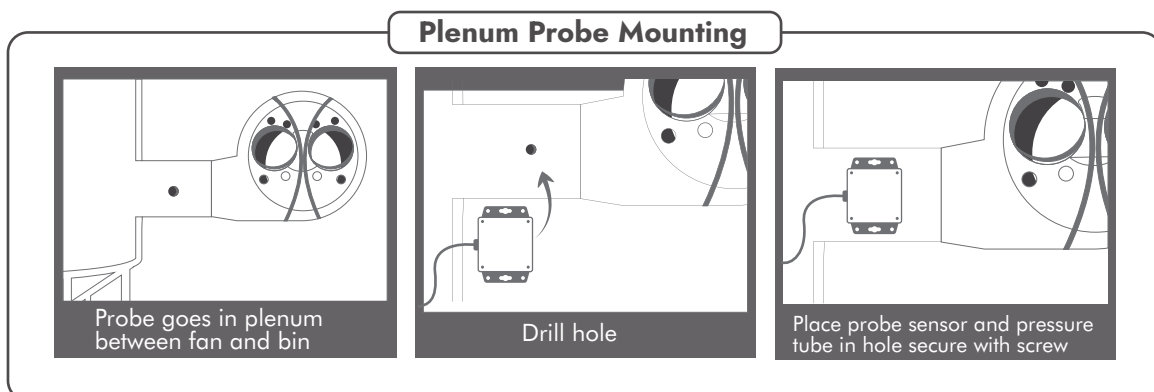

AMBIENT SENSOR

Part ID AS001

The Ambient Sensor is designed to assist farmers with Hydrating Grains in the Bin. The Ambient Sensor measures accurate outdoor temperature and humidity and is used to automate the Aeration fan process.

Sensor Shielding

The Radiation Shield encases the sensor to ensure the most accurate readings possible for the best results.



Fully Compatible

The Ambient Condition Sensor is fully compatible with all Adaptive Smart Devices and plugs into the same port as a grain cable.

HEADSPACE CO2 SENSOR

Part ID HS001

Measuring CO₂ in a grain bin is a valuable practice as it provides essential insights into the condition of stored grains. Elevated levels of CO₂ can indicate potential issues such as spoilage, mold growth, or insect infestations within the bin. By monitoring CO₂ levels, farmers can detect these problems early on, enabling timely interventions to prevent further damage and preserve grain quality.



CO2 AND LIDAR INVENTORY SENSOR



The combined CO2 and LiDAR Sensor provides CO2 levels as well as inventory levels within 1cm of accuracy. The LiDAR laser level sensor is equipped with a wiper that will wipe dust off the optical lens ensuring optimal readings throughout the season. CO2 is used as an early indicator of spoilage which will trigger up to 10 days before a grain cable will show a heat warning. The sensor also provides headspace temperature and relative humidity readings which can indicate condensation or trigger and exhaust fan to remove excess humidity.

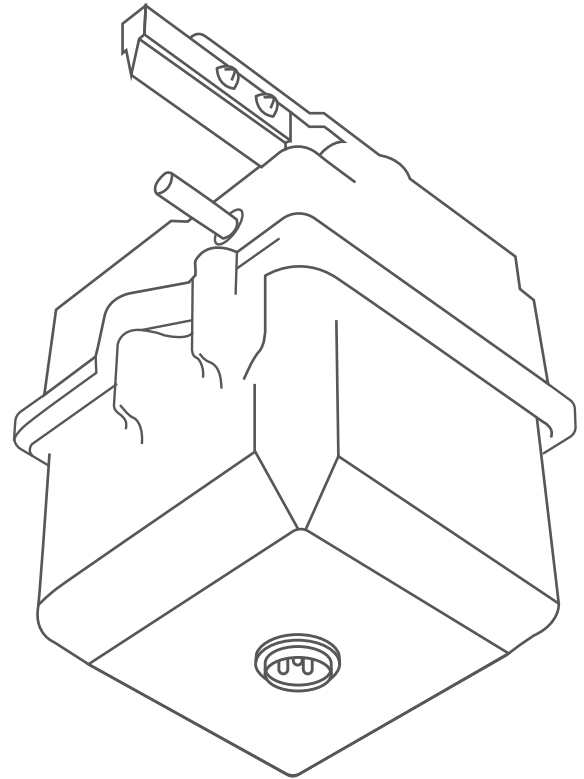
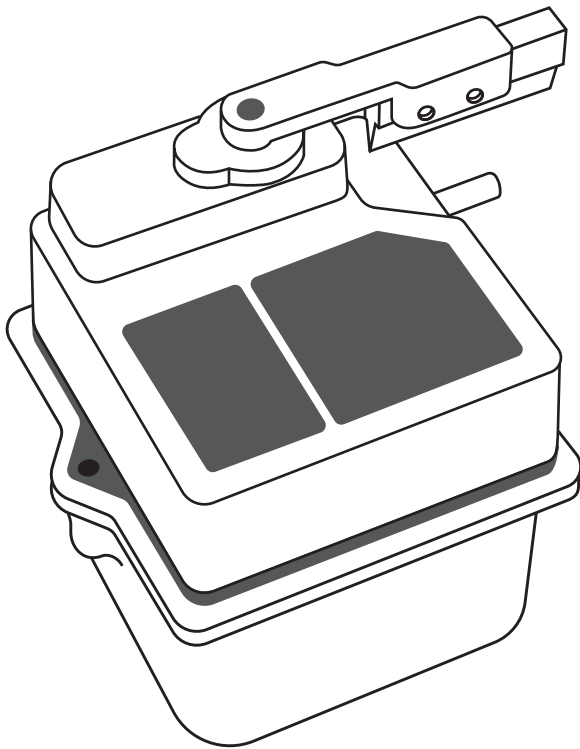

HEATER+ CONTROL MODULE

Part ID HTC001

The **Heater+ Control Module** expands an Adaptive Smart Device to automate a supplemental heater to introduce controlled dry air into the grain bin for the purpose of In-Bin Drying. A Plenum Sensor is required to regulate the supplemental heater and automate the **In-Bin Drying** process.

Plug-And-Play

Connect the Heater+ Module to the Control Output Port on any Adaptive Smart Device for seamless control and automation.



Heater Connection

The heater connection plugs directly into the 'thermostat' port on common Construction Heaters.

AERATION + CONTROL MODULE

Part ID AFC001

The **Aeration+ Control Module** expands the Adaptive Smart Devices to remotely control or automate the aeration operation based on Ambient or Plenum Sensor conditions.

Note: Ambient Sensor is required for Grain Hydration and Plenum Sensor is required for In-Bin Drying.

Plug-And-Play

Connect an Adaptive Smart Device (required) to the device port for remote control or automation of the Aeration Fan.

Auto / Manual Mode

Switch toggle allows you to switch between **Manual** use of the fan (using the fan start switch) and **Auto** which will listen to the Smart device and turn on remotely/automatically (based on sensor data)

Simple Aeration Install

Four (4) wires need to be wired into your existing aeration fan to gain remote control of the Aeration Fan. Wiring schematics are available for several common farm fans.



ADAPTER PLATES

Part ID BAP001

The Patented 2-piece Adapter Plate is the safest way to attach a Construction Heater onto your Aeration Fan. We worked with HVAC Engineers to ensure the proper amount of mixed airflow enters the fan and we have continually seen successful grain drying since 2019 with these plates!

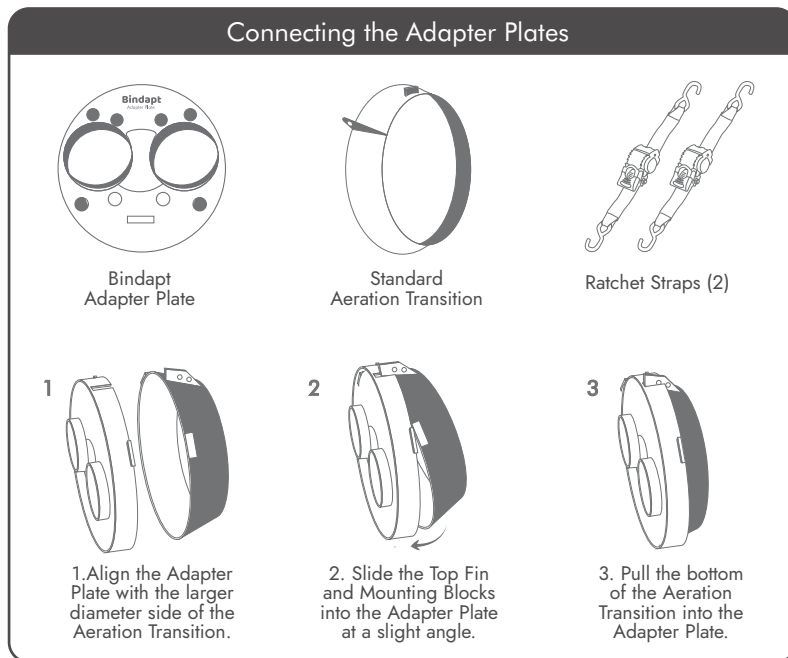

AERATION TRANSITIONS

Part ID BAT001, BAT002, BAT003

The Aeration Transition is the second piece of the Adapter Plate that interfaces with the fan and the front plate the heater attaches to. The standard Adapter Plate comes with a first transition for fans between 3hp and 7.5hp. For fans above 10HP the middle aeration transition is required in order to not starve the inlet of the fan.

The largest Aeration Transition is for BIG flat bottom bins and has 2 addition ports for ANOTHER construction heater. Using two construction heaters we have seen significant drying on bins With high CFM/Low speed fans.

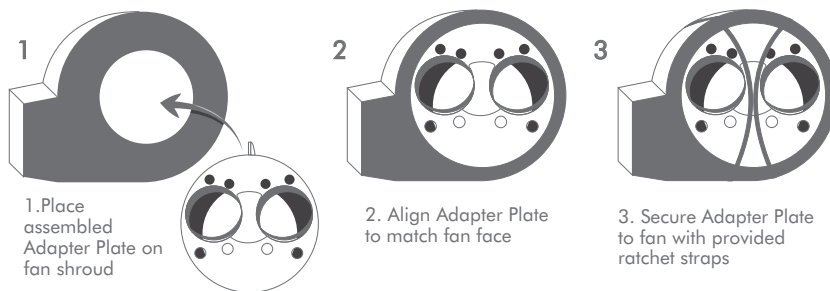
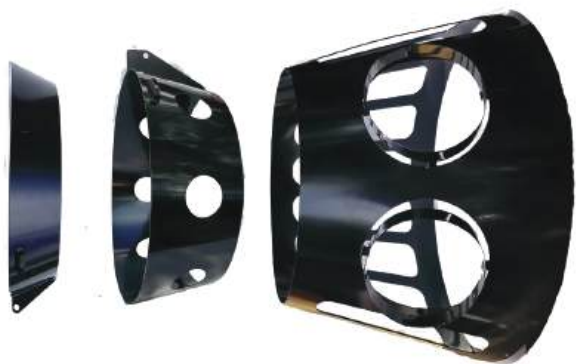

VISUAL FARM PLATFORM FEATURES:

Bins: Inventory Management

Adaptive Agriculture's online platform offers a robust bin management and inventory feature that streamlines the tracking and management of agricultural produce. This feature allows users to efficiently monitor the status and condition of storage bins, ensuring optimal storage conditions and reducing the risk of spoilage or waste. Users can easily record and update inventory levels, track crop quality, and receive real-time alerts for temperature and humidity fluctuations.



With Adaptive Agriculture's bin management and inventory feature, farmers and agricultural professionals can enhance their operational efficiency and make informed decisions to maximize the quality and value of their stored crops.

One-Click Bin Modes: Drying, Hydrating, Cool-down & Storage

The Bindapt+ system offers users a seamless and convenient way to manage their grain storage with its innovative "one-click" bin modes. With just a single click, users can automate the entire aeration process, ensuring their grain is optimally conditioned for different stages. Whether it's drying, hydrating, initiating a cool-down, or preparing for storage, these one-click bin modes simplify the complex task of grain management.



This user-friendly feature not only saves time and effort but also helps maintain grain quality by precisely controlling aeration and temperature conditions throughout the storage process. Bindapt+ empowers users to achieve efficient and reliable grain conditioning with ease, enhancing the overall quality and value of their stored grains.

Plot your Bins and Bin Yards

Adaptive Agriculture's visual map feature empowers users to accurately plot their bin yards and bins on a digital map, ensuring precise location tracking. With this feature, users can easily create a visual representation of their agricultural storage facilities, marking the exact positions of individual bins. This functionality simplifies logistics, allowing users to efficiently organize their bin yards and optimize workflows.

By visualizing their storage infrastructure on the map, users can also make data-driven decisions about bin placement, facilitating better resource allocation and crop management. Overall, the visual map feature enhances the precision and efficiency of agricultural operations, helping users make the most of their storage facilities.



Map your Fields: Scouting and Crop Traceability

The Field Mapping and Scouting feature within the Adaptive Agriculture Visual Farm platform is a powerful tool that offers farmers a comprehensive view of their fields and enables precise traceability from the field to the bin. This feature allows users to create detailed maps of their fields, marking key information such as crop varieties, pest hotspots, and irrigation zones. By meticulously tracking these details, farmers gain valuable insights into field conditions and can make informed decisions to optimize crop management.

Moreover, this traceability extends seamlessly from the field to the bin, ensuring that every harvested crop can be precisely linked to its origin. This level of precision not only enhances crop quality control but also facilitates compliance with traceability standards, assuring end-to-end transparency and accountability in the agricultural supply chain.



Teams: Collaborate as a Team in one place

The Team features of the Visual Farm platform are designed to enhance collaboration and streamline farm management by enabling multiple users to work together seamlessly. With the Team feature, all users can access, edit, and manage the same farm data, fostering real-time collaboration among team members. What sets it apart is the ability to create different levels of access, ensuring that users have appropriate permissions while safeguarding sensitive information. Moreover, this feature serves as a centralized hub for farm communication, as it allows users to maintain farm-wide notes within the same platform. By consolidating farm-related discussions and data, the Team feature enhances communication efficiency and overall farm productivity, making it an invaluable tool for modern agricultural operations.

Platform Integrations: Forward Looking

The future integrations planned for Visual Farm are set to revolutionize farm management by seamlessly connecting with industry-leading platforms such as John Deere Operations Center and Case New Holland. These integrations will empower users to retrieve critical data, including field mappings, harvest data, and machinery information, in near-real time. By harnessing the power of these well-established systems, Visual Farm will provide farmers with comprehensive insights and operational efficiencies. This forward-looking approach underscores Visual Farm's commitment to staying at the forefront of agricultural technology, enabling users to make more informed decisions, optimize their workflows, and ultimately maximize their farm's productivity and profitability through data-driven precision agriculture.